



Data Sheet

RISH DMC*i*



Measure



Control



Record



Analyze

RISH DMCi is a smart Demand Monitor and controller which controls the Active, Reactive, Apparent or Current Demand within the allowed limits and helps to save money on utility bills. This instrument prevents consumption of excess power or peaks resulting in higher penalties. It provides the simulation feature allowing one to enter the load values and verify the system conditions prior to installation.

Product Features:

Demand Measurement and Control:

- ☞ W, Var, VA and Current Demand
- ☞ Controlling with any selected parameter
- ☞ Selectable window type - Fixed or Sliding
- ☞ Demand Period selectable from 1 to 60 minutes
- ☞ Predictive Demand Control for faster controlling action even before completion of present demand interval
- ☞ Demand Control with separate load shedding thresholds for each tariff zone
- ☞ All Max Demand (W, VAr, VA & Current) parameters are stored with Date and Time stamp
- ☞ OLD Max Demand Storage

Control Outputs:

- ☞ 4Relay Outputs for efficient Demand Control and Management

Measures & Monitors more than 80 parameters:

- ☞ All basic electrical parameters
- ☞ Individual harmonics contents of per phase voltage and current.
- ☞ Onsite programmable CT ratio & PT ratio and system configuration
- ☞ Wide auxiliary power supply range: 60-300VAC/DC

True RMS measurement:

- ☞ The instrument measures distorted waveform upto 56th Harmonic for 50Hz and upto 46th Harmonic for 60Hz

Power Quality Measurement:

- ☞ Measurable up to 56th (50Hz) harmonic on each phase. Maximum any 6 harmonics can be monitored simultaneously for each phase
- ☞ Measurement of RMS value of fundamental and per phase voltage and current harmonics
- ☞ (%) THD of per phase voltage and current
- ☞ Distortion factor of individual harmonics

Real Time Clock (RTC):

- ☞ Displays date and time

Run Hour, ON Hour, Number of Interruptions:

- ☞ displays parameters for utility

Graphical Analysis:

- ☞ Per phase individual harmonic bar graph representation
- ☞ Real time vector representation of all 3 Phases for complete system analysis.

Energy 0.5S as per IEC 62053:

- ☞ Independent Import and Export energy counter
- ☞ Active energy (kWh), Fundamental Reactive energy (kVArh) and Apparent energy (kVAh) measurement
- ☞ Accuracy Class 0.5S as per IEC 62053-22, IEC62053-23

Time Of DAY (TOD / TOU):

- ☞ Easy programmable tariff schedule
- ☞ 4 seasons, 4 tariffs, 6 time zones per day, 4 types of days, 5 tariff energy register
- ☞ Automatic daily profile storage for a one day, one month & one year
- ☞ Cost per kWh calculation

Direct remote access via MODBUS:

- ☞ Remote access of measured and configuration parameters
- ☞ User Assignable Registers for MODBUS
- ☞ Programmable baud rates up to 38.4kbps

Custom color setting:

- ☞ User can assign individual colour for each phase as per the application requirement through display and MODBUS

Onsite programmable for user desired application:

- ☞ Onsite programmable input voltage (100V_{LL} to 500 V_{LL}), input current (1A or 5A) and system configuration (3 phase 4Wire (unbalanced) or 3phase 3Wire (unbalanced) network).
- ☞ Onsite programmable CT ratio & PT ratio.
- ☞ Wide auxiliary power supply range: 60-300VAC/DC.

Old Register:

- ☞ this register holds the value before the last reset . The old value will be available when scrolled through screen.

Compliance to International Safety standards:

- ☞ compliance to International Safety standard IEC 61010-1-2010

EMC Compatibility:

- ☞ Compliance to International standard IEC 61326.



Measure



Control



Record



Analyze

Dimensions Details:

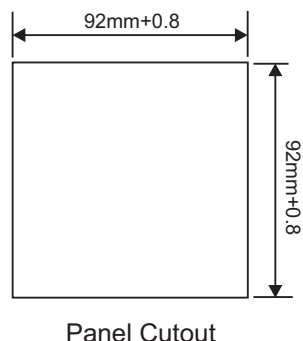
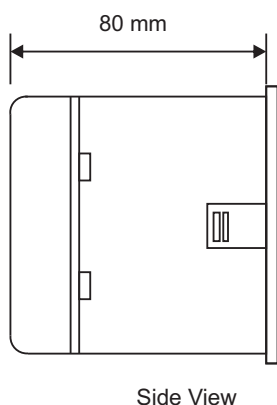
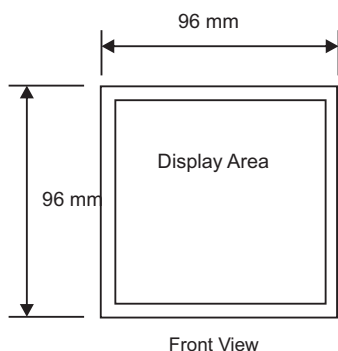

Technical Specifications:

Accuracy :

Active Energy	Class 0.5S as per IEC 62053 - 22
Apparent Energy	Class 0.5S as per IEC 62053 - 22
Fundamental Reactive Energy	Class 2 as per IEC 62053 - 23
Reference conditions (As per. IEC/EN 60688) :	
	Ambient 23°C ± 1°C
	Sinusoidal (distortion factor 0.005), 50 / 60 Hz
Active Power	±0.2% of Nominal value
Fundamental Reactive Power	±0.2% of Nominal value
Apparent Power	±0.2% of Nominal value
Power Factor / Phase Angle	±2°
Voltage	±0.2% of Nominal value
Current	±0.2% of Nominal value
Frequency	±0.1% of mid frequency
Harmonics	±1.0%
THD Voltage / Current	±1.0%

Input Voltage:

Nominal input voltage (AC RMS)	57.7 - 288.68 V _{L-N} On site Programmable (Line-Line 100 - 500 V _{L-L})
System PT primary values	100V _{LL} to 692.8 kV _{LL} On site Programmable
Max continuous input voltage	347 V _{LN} , 600 V _{LL}
Voltage Measuring Range	5 V _{LN} 347 V _{LN} , 9 V _{LL} 600 V _{LL} .
Overload Withstand	2x times of Nominal voltage for 1 second, repeated 10 times at 10 second intervals
Frequency Measuring Range	45Hz to 66Hz

Input Current:

Nominal input current	1A / 5A AC RMS On site Programmable
System CT primary values	From 1A up to 9999A On site Programmable
Max continuous input current	120% of Nominal value
Current Measuring Range	5% to 120% of Nominal current.
Overload Withstand	20x times of Nominal current for 1 second, repeated 5 times at 5 min intervals
Starting Current for energy as per IEC 62053-22 class 0.5S	1 mA for 1A range 5 mA for 5A range

Auxiliary Supply:

External Aux	60 V – 300V AC-DC
Aux supply frequency	50 / 60 Hz (± 10 %)

VA Burden:

Nominal input voltage burden	< 0.2 VA approx. per phase
Nominal input current burden	< 0.2 VA approx. per phase
Auxiliary Supply burden	< 6.5 VA approx



Measure



Control



Record



Analyze

Electrical Connection:

Network Types :

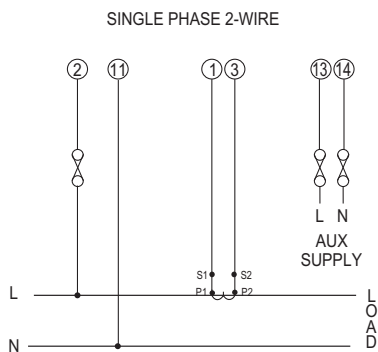
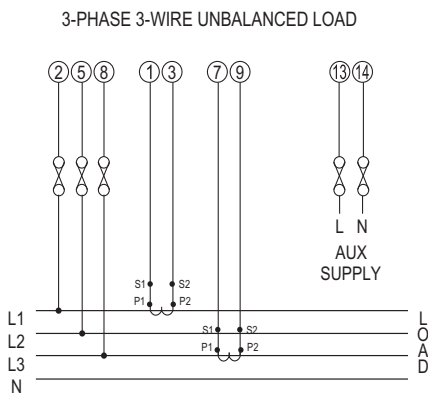
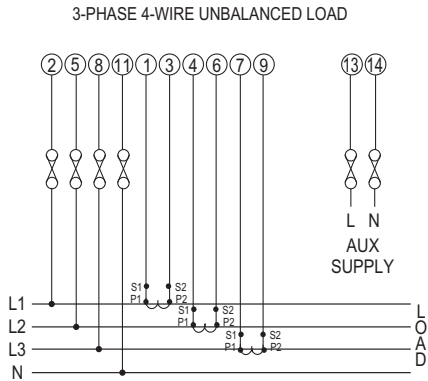

It is recommended that the wires used for connections to the instrument should have lugs soldered at the end. That is, the connections should be made with Lugged wires for secure connections. The Maximum diameter of the lug should be 7.0 mm and maximum thickness 3.5mm.

Technical Specifications:

Real Time Clock (RTC):

Uncertainty ± 2 minutes / month ($23^{\circ}\text{C} \pm 1^{\circ}\text{C}$)
(trimmable through display or Modbus)

Display Update Rate:

Response time to step input 1 sec approx.

Applicable Standards:

EMC	IEC 61326
Immunity	IEC 61000-4-3. 10V/m min – Level 3 industrial Low level
Safety	IEC 61010-1-2010 , Permanently connected use
IP for water & dust	(IP 54 for Front) IEC60529
Pollution degree:	2
Installation category:	III
High Voltage Test (DC,1 minute)	5.23 kV DC between all other Electrical circuits

Environmental Conditions, Other information:

Operating temperature	-10 to +55°C
Storage temperature	-20 to +65°C
Relative humidity	0... 95% non condensing
Warm up time	Minimum 3 minute
Shock	15g in 3 planes
Vibration	10... 150.... 10 Hz, 0.075mm amplitude
Temperature Coefficient	0.05%/°C

Interfaces

Relay	Used as Control Output
Load Capacity	240 V AC, 5 A
Contact	Change over contact, bistable
Mechanical Endurance	1×10^6 operations
Electrical Endurance (240V, 5A)	1×10^5 operations
ModBus / RTU	RS485,max. 1200m Baud rate: 4.8k, 9.6k, 19.2k, 38.4k bps



Measure



Control



Record



Analyze

Display Parameter:

✓ : Available

* : Not Available

Sr No	Displayed Parameters	3 Phase 4Wire	3Phase 3Wire	1 Phase 2Wire
1.	System Voltage	✓	✓	✓
2.	System Current	✓	✓	✓
3.	Volts L1 – N	✓	*	✓
4.	Volts L2 – N	✓	*	*
5.	Volts L3 – N	✓	*	*
6.	Volts L1 – L2	✓	✓	*
7.	Volts L2 – L3	✓	✓	*
8.	Volts L3 – L1	✓	✓	*
9.	Current L1	✓	✓	✓
10.	Current L2	✓	✓	*
11.	Current L3	✓	✓	*
12.	Neutral Current	✓	*	*
13.	Frequency	✓	✓	✓
14.	System Active Power (kW)	✓	✓	✓
15.	Active Power L1 (kW)	✓	*	✓
16.	Active Power L2 (kW)	✓	*	*
17.	Active Power L3 (kW)	✓	*	*
18.	System Fundamental Reactive Power (kVAr)	✓	✓	✓
19.	Fundamental Reactive Power L1 (kVAr)	✓	*	✓
20.	Fundamental Reactive Power L2 (kVAr)	✓	*	*
21.	Fundamental Reactive Power L3 (kVAr)	✓	*	*
22.	System Apparent Power (kVA)	✓	✓	✓
23.	Apparent Power L1 (kVA)	✓	*	✓
24.	Apparent Power L2 (kVA)	✓	*	*
25.	Apparent Power L3 (kVA)	✓	*	*
26.	System Power Factor	✓	✓	✓
27.	Power Factor L1	✓	*	✓
28.	Power Factor L2	✓	*	*
29.	Power Factor L3	✓	*	*
30.	Phase Angle L1	✓	*	✓
31.	Phase Angle L2	✓	*	*
32.	Phase Angle L3	✓	*	*
33.	Import kWh (Up to 14 digit resolution)	✓	✓	✓
34.	Export kWh (Up to 14 digit resolution)	✓	✓	✓
35.	Fundamental Import kVArh (Up to 14 digit resolution)	✓	✓	✓
36.	Fundamental Export kVArh (Up to 14 digit resolution)	✓	✓	✓
37.	kVAh (Up to 14 digit resolution)	✓	✓	✓
38.	Current Demand	✓	✓	✓
39.	kVA Demand	✓	✓	✓
40.	kW Import Demand	✓	✓	✓
41.	kW Export Demand	✓	✓	✓
42.	Fundamental Import kVAr Demand	✓	✓	✓
43.	Fundamental Export kVAr Demand	✓	✓	✓
44.	Max Current Demand	✓	✓	✓
45.	Max kVA Demand	✓	✓	✓
46.	Max kW Import Demand	✓	✓	✓
47.	Max kW Export Demand	✓	✓	✓
48.	Max Fundamental Import kVAr Demand	✓	✓	✓
49.	Max Fundamental Export kVAr Demand	✓	✓	✓
50.	Run Hour	✓	✓	✓



Measure



Control



Record



Analyze

Display Parameter:

✓ : Available

✗ : Not Available

Sr No	Displayed Parameters	3 Phase 4Wire	3Phase 3Wire	1 Phase 2Wire
51.	On Hour	✓	✓	✓
52.	Number of Interruption	✓	✓	✓
53.	Phase Reversal Indication	✓	✗	✗
54.	Phasor Diagram	✓	✗	✓
55.	Voltage Waveform	✓	✓	✓
56.	Current Waveform	✓	✓	✓
57.	% THD Voltage L1-N	✓	✗	✓
58.	% THD Voltage L2-N	✓	✗	✗
59.	% THD Voltage L3-N	✓	✗	✗
60.	% THD Voltage L1-L2	✗	✓	✗
61.	% THD Voltage L2-L3	✗	✓	✗
62.	% THD Voltage L3-L1	✗	✓	✗
63.	% THD Current L1	✓	✓	✓
64.	% THD Current L2	✓	✗	✗
65.	% THD Current L3	✓	✓	✗
66.	% THD Voltage Mean	✓	✓	✗
67.	% THD Current Mean	✓	✓	✗
68.	RMS voltage of Harmonics	✓	✓	✓
69.	RMS Current of Harmonics	✓	✓	✓
70.	Fundamental Active Power per phase	✓	✗	✓
71.	Fundamental Reactive Power per phase	✓	✗	✓
72.	Fundamental Apparent Power per phase	✓	✗	✓
73.	Fundamental Power Factor per phase	✓	✗	✓
74.	Individual Harmonic Active Power per phase	✓	✗	✓
75.	Individual Harmonic Reactive Power per phase	✓	✗	✓
76.	Individual Harmonic Apparent Power per phase	✓	✗	✓
77.	Distortion Factor of all harmonics on phase voltage	✓	✓	✓
78.	Distortion Factor of all harmonics on phase Current	✓	✓	✓
79.	Power Factor of Individual Harmonic per phase	✓	✗	✓
80.	Fundamental voltage RMS per phase	✓	✓	✓
81.	Fundamental current RMS per phase	✓	✓	✓

Ordering Information:

Ordering information	Ordering Code
System Type (Connection Network)	
3 Phase	3
1 Phase	1
Communication Interface	
Without MODBUS (RS485) output	NM
With MODBUS (RS485) output	M

Order Code Example:

RISH DMC 3 - M

RISH DMC 3 Phase, with MODBUS (RS485) Output



Measure



Control



Record



Analyze



RISHABH



Measure



Control



Record



Analyze

RISHABH INSTRUMENTS PVT. LTD.

Trishala Unit, C-6, NICE Area, MIDC, Satpur, Nashik - 422007, India.

Tel: +91 253 2202371 / 028 | Fax: +91 253 2351064 | E-mail: marketing@rishabh.co.in | www.rishabh.co.in